

ORDERING INFORMATION

ECRS - **50S** - **0**

Flange
F Flange
0 No Flange

Rotation
R Right (Clockwise)
L Left (Counter-Clockwise)

Standard component call out includes:

- (1) Dual Cylinder switch P/N MK5351
- M-12 4 Pin Eurofast Connector shipped S1 extended. Click for details
- (1) Clamp Finger (shown)
- (4) SHCS M-6 x 130 used to mount clamp from either direction or attach flange to either end.

Optional Mounting Flange 12 Thick

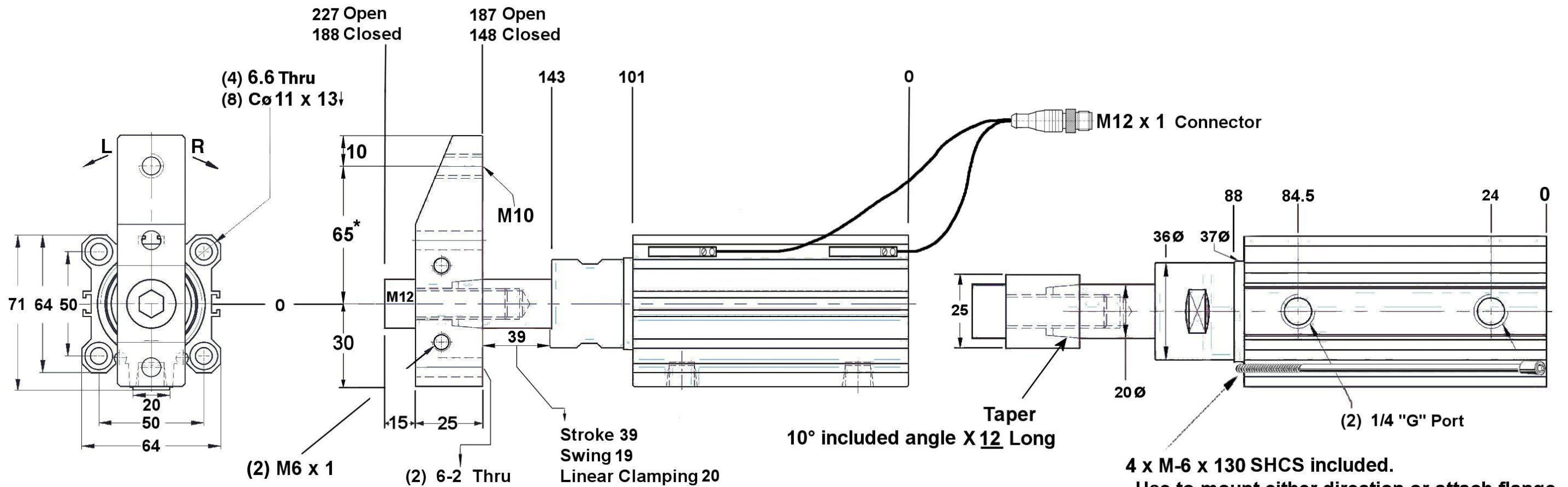
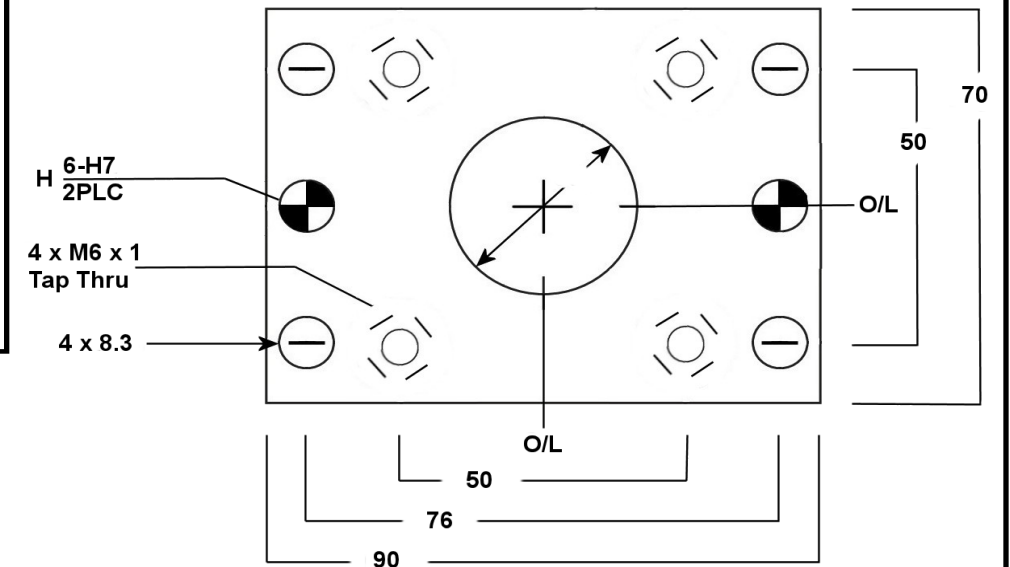

*Custom Fingers Max. Length 98mm / Max. Weight 1.5kg (3.5 lbs.)

Clamps come with standard finger shown. 90° standard rotation (contact us for options).

Operating Pressure: Max. 7kgf, cm2, 7BAR, 100 PSI / Min. 4kgf / cm2, 4BAR, 60 PSI

Clamping Pressure: Min. 76kgf, 170lbf / Max. 116kg 255lbf

Calculated Metric: Bar ____ x 6 = ____ kgf Imperial PSI ____ x .9 = ____ lbf

	<small>NOTICE: THIS DRAWING IS PROPERTY OF E&E CUSTOM PRODUCTS INCLUDING THE PRINCIPLES OF THE DESIGN INVOLVED, AND IS SUBMITTED WITH AGREEMENT THAT IT IS NOT TO BE REPRODUCED, COPIED, OR LOANED, IN PART OR WHOLE, ACCEPTANCE OF THIS DRAWING WILL BE CONSTRUED AS AN AGREEMENT TO THE ABOVE</small>		
	TITLE CRS50 Compact Rotashaft (50mm Bore) Short		
	PART NO.		
	DRAWN BY:	CHK'D BY:	APPR'D BY:
7200 MILLER DR. WARREN, MI 48092 EE-CP.COM	DATE:	DATE:	
SCALE: 1/2	DWG. NO. CRS50 Compact Rotashaft - LONG		
SHT 1 OF 1			